

SERPAC 15-S

Electronics Enclosures

NOTES:

1. WHEN MACHINE OR I PLATES MODIFICATIONS ARE REQUIRED, USE THE CENTER OF THE ENCLOSURE TO DIMENSION.

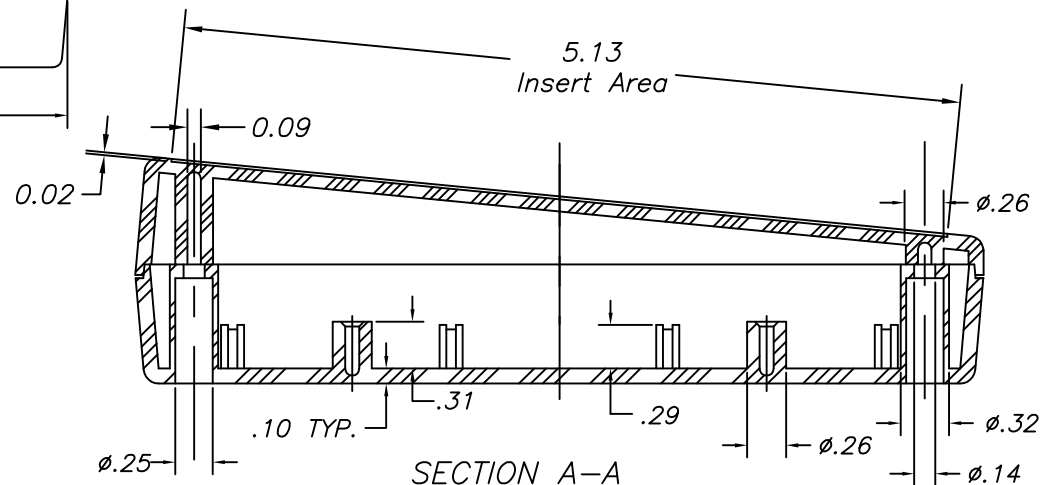
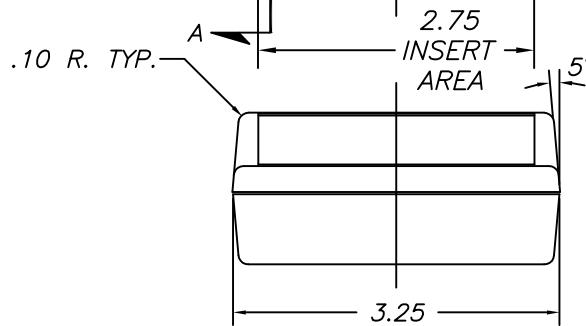
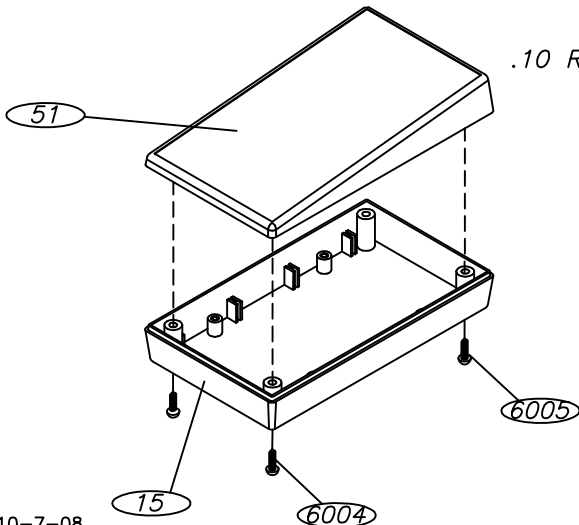
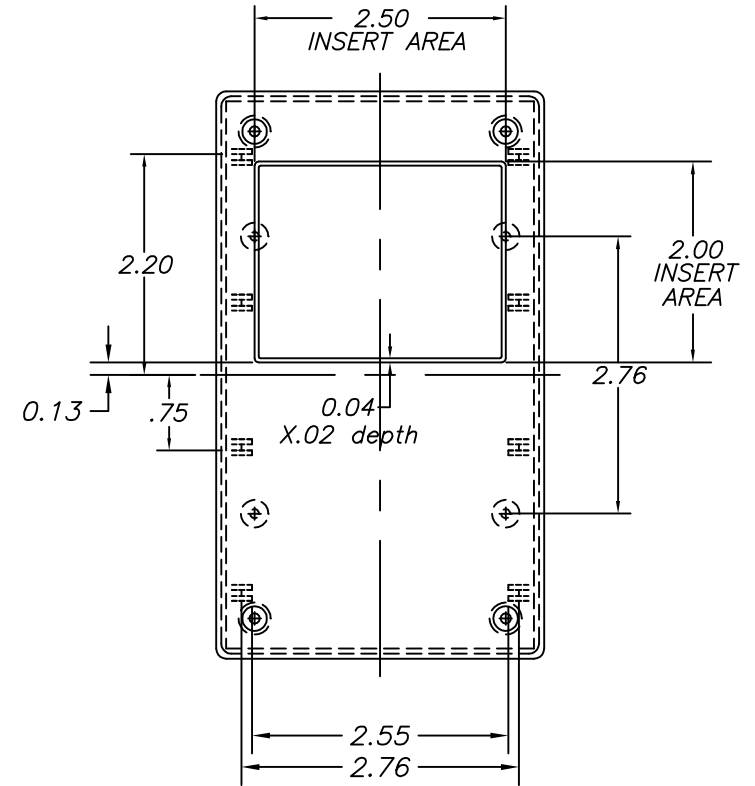
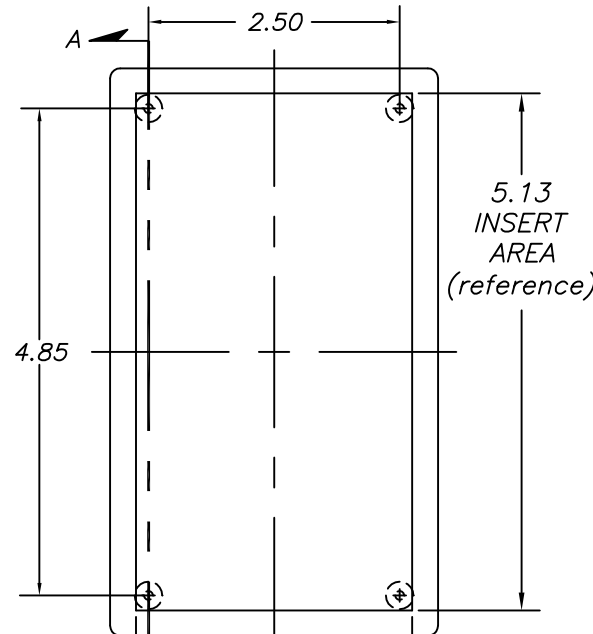
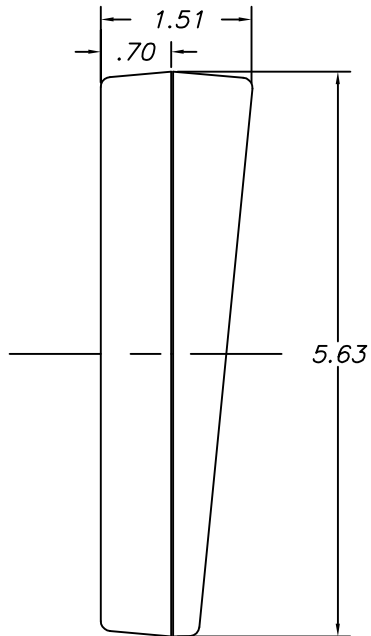

10-7-08

ALL DIMENSIONS ± .010

PART NO.	DESCRIPTION	ACCESSORIES	
5S	PLASTIC TOP	PART NO.	DESCRIPTION
15	PLASTIC BOTTOM	50	FEET
6013	SCREWS (2) Shallow end	350	PROTOTYPE GRID BOARD (HORIZ.)
6005	SCREWS (2)	450	PROTOTYPE CLAD BOARD (HORIZ.)
		351	PROTOTYPE GRID BOARD (VERT.)
		451	PROTOTYPE CLAD BOARD (VERT.)
		PC	POCKET CLIP